

# WIRING THE *RCS* PRO-6T ESC using track power **AND** battery back up.

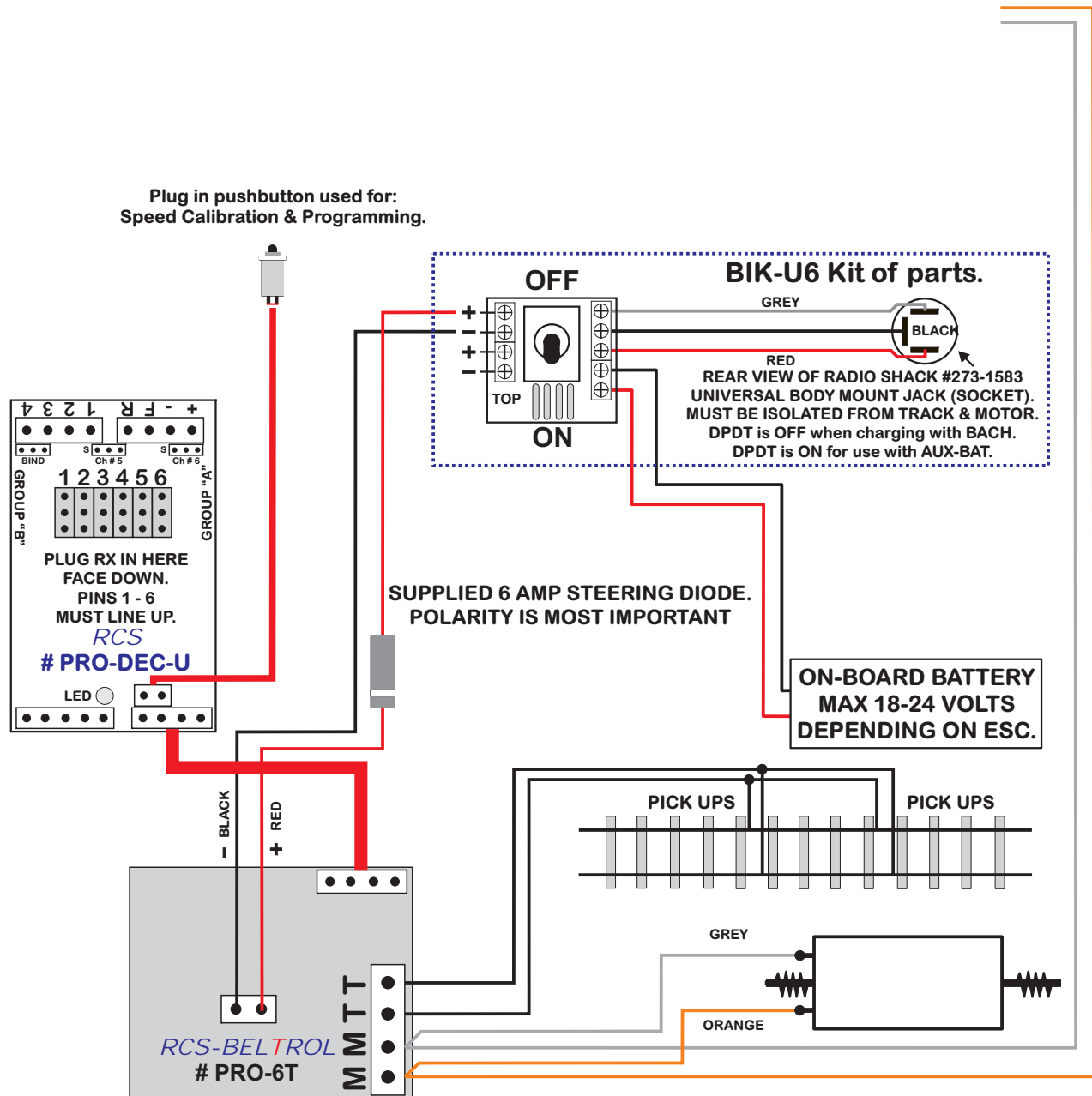

## CAUTION:

SPEKTRUM® R/C & PLANET TWISTER® R/C ARE GROUP "A" SYSTEMS.  
THEY MUST USE THE PRO-Av1 PROGRAM.  
HOBBY KING® R/C & E-SKY® R/C ARE GROUP "B" SYSTEMS.  
THEY MUST USE THE PRO-Bv1 PROGRAM.