

WIRING THE **RCS-BELTROL** ECL-6r ESC with battery power only. How to wire incandescent & LED lights.

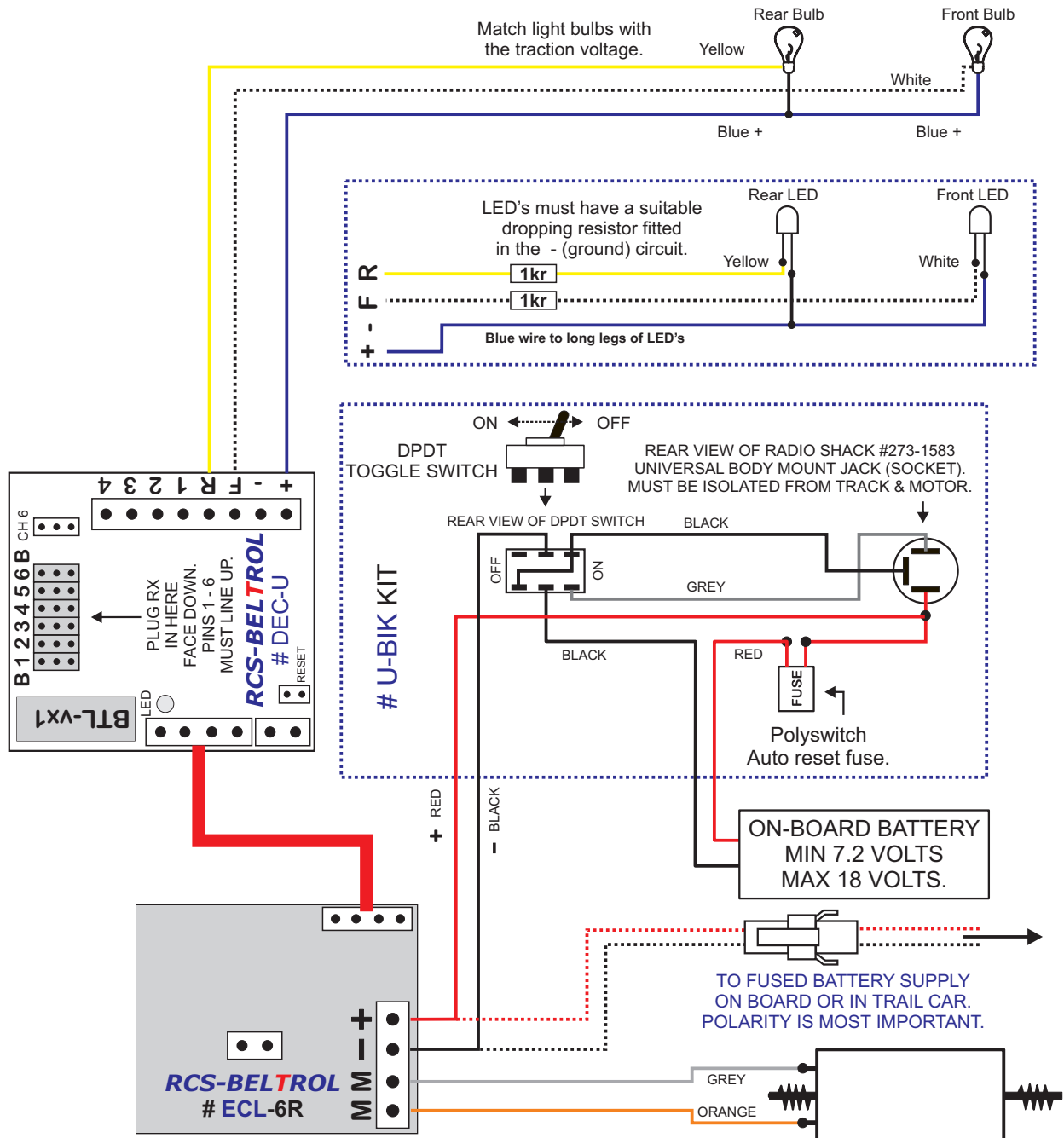

CAUTION:

SPEKTRUM® R/C & PLANET TWISTER® R/C ARE GROUP "A" SYSTEMS.
THEY MUST USE THE BTLvA1 PROGRAM.
HOBBY KING® R/C & E-SKY® R/C ARE GROUP "B" SYSTEMS.
THEY MUST USE THE BTLvB1 PROGRAM.