

# WIRING THE *RCS-BELTROL* BTL-6r ESC with battery power & MyLocosound.

**N.B. It is OK to swap outputs #1, #2, #3 & #4 to suit TX sticks.**

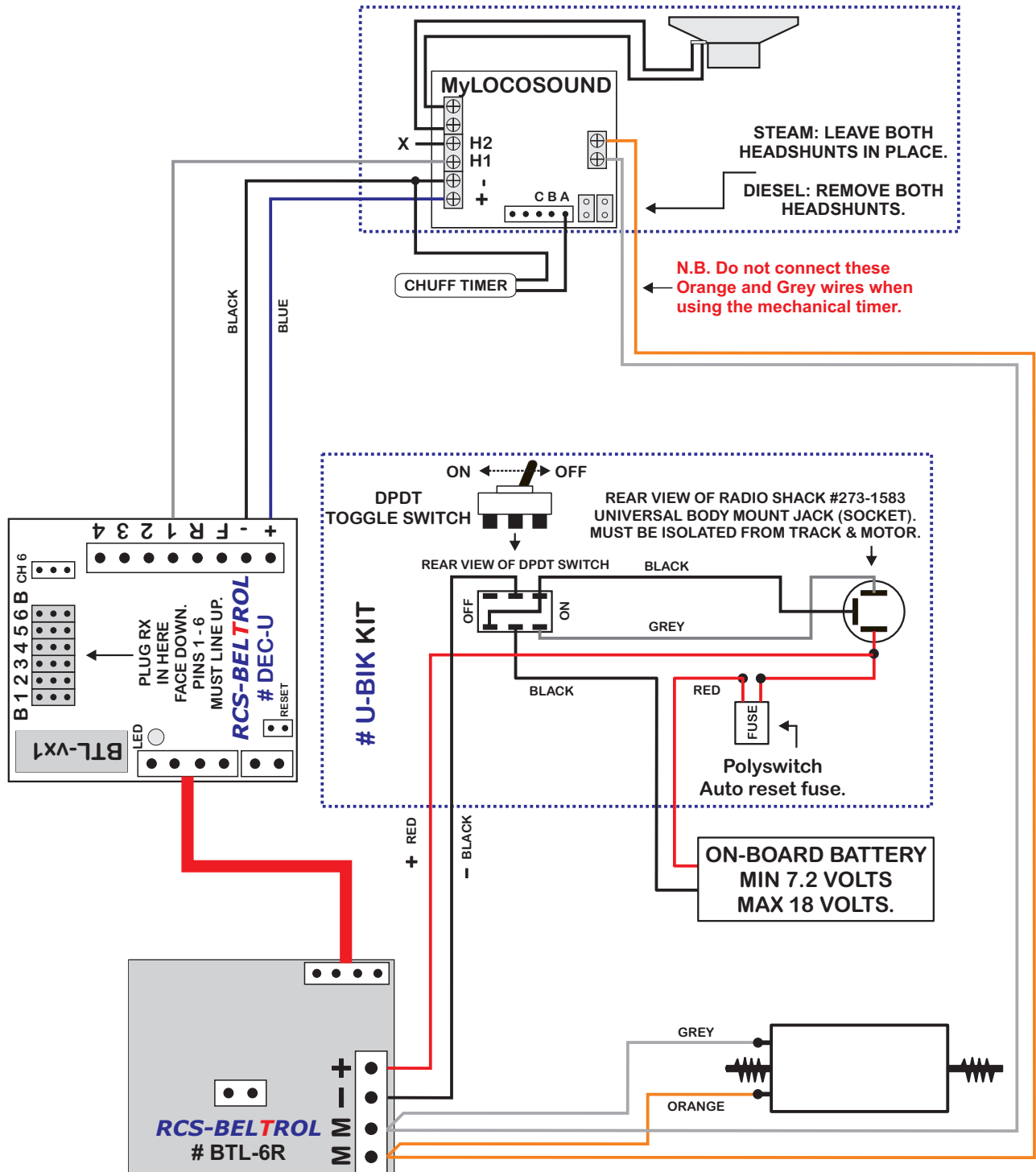

## CAUTION:

SPEKTRUM® R/C & PLANET TWISTER® R/C ARE GROUP "A" SYSTEMS.  
 THEY MUST USE THE **BTLvA1** PROGRAM.  
 HOBBY KING® R/C & E-SKY® R/C ARE GROUP "B" SYSTEMS.  
 THEY MUST USE THE **BTLvB1** PROGRAM.