

WIRING THE *RCS-BELTROL* BTL-3r ESC with battery power & Phoenix P8 sound.

N.B. It is OK to swap outputs #1, #2, #3 & #4 to suit TX sticks.

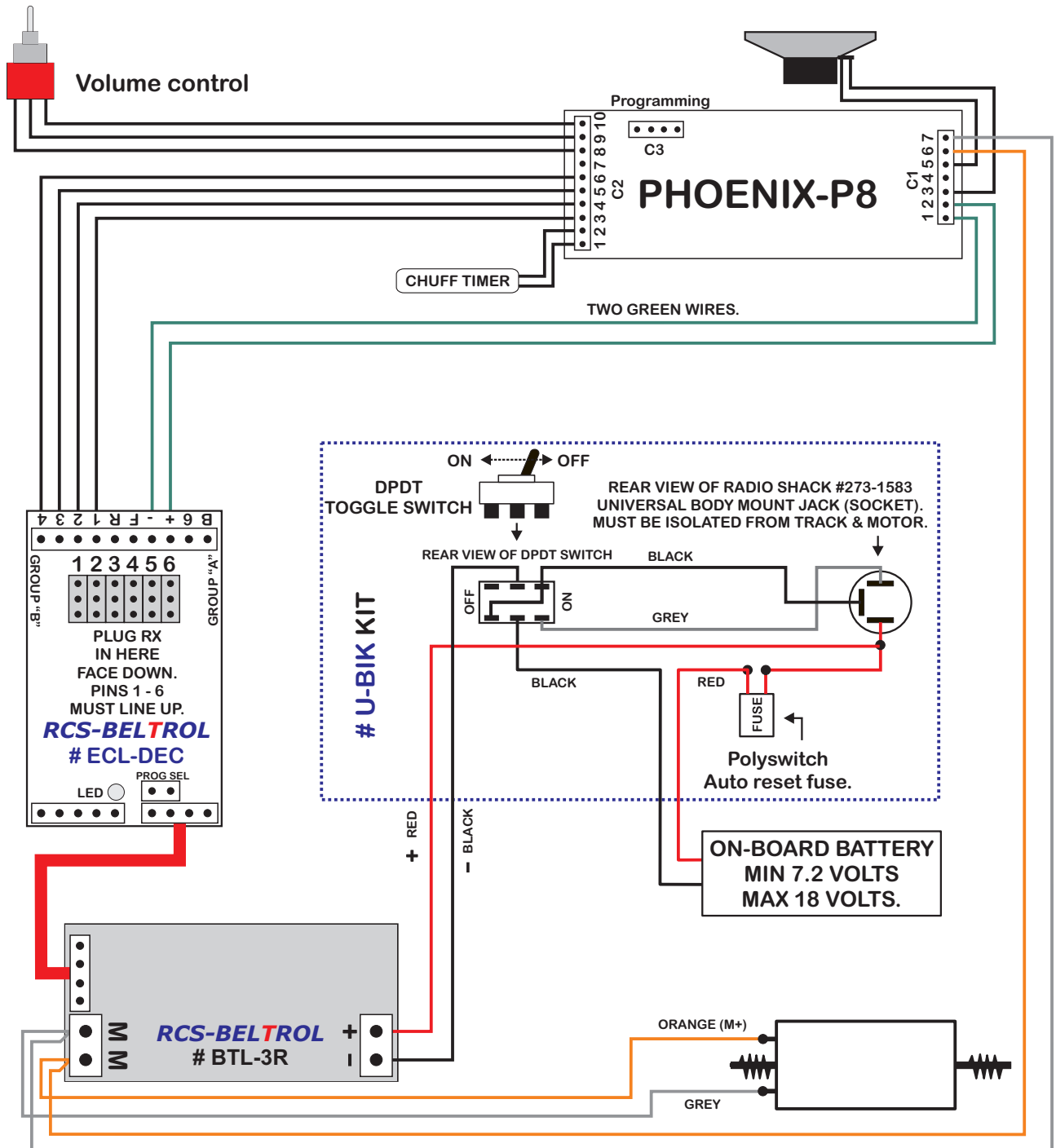

CAUTION:

SPEKTRUM® R/C & PLANET TWISTER® R/C ARE GROUP "A" SYSTEMS.
 THEY MUST USE THE BTLvA2 PROGRAM.
 HOBBY KING® R/C & E-SKY® R/C ARE GROUP "B" SYSTEMS.
 THEY MUST USE THE BTLvB2 PROGRAM.